

# IMPATT Diodes and Test Fixtures

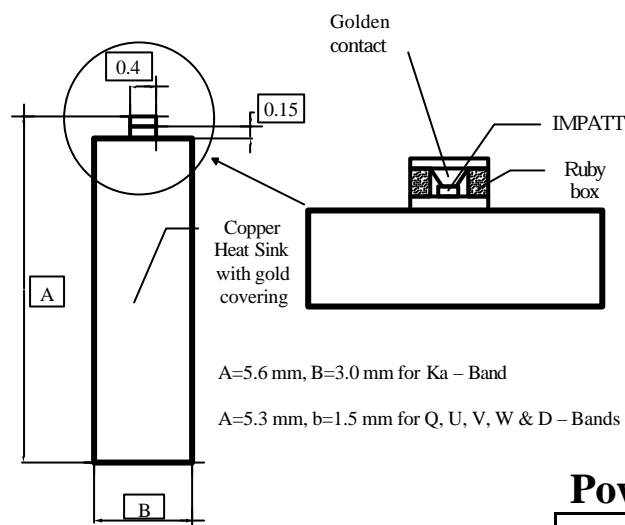

- 25-155 GHz frequency range
- Pulse and CW version
- 20W pulse, 200 mW CW operation
- Delivery from stock
- Low cost

## Power output available

Frequency (GHz)	33-37	42-46	54-62	92-96	135-155
CW, mW	200	200	200	150	50
Pulse ,W	20	Call	20	20	2

## Description

ELVA-1 series of IMPATT diodes are silicon double drift diodes mounted in hermetically sealed packages and supplied mounted to a copper heat sink. Standard products are offered with power outputs tested in specific frequency windows.

IMPATT diode products for millimeter-wave applications are realized on the basis of the symmetrical double-drift structure. The layers in double-drift diodes are: a heavily doped (p<sup>+</sup>)-region, a moderately doped p-region, a moderately doped n-region, and a heavily doped (n<sup>+</sup>)-region. The (p<sup>+</sup>)- and (n<sup>+</sup>)- regions allow ohmic electrical contacts to be made to the external circuit. Two p- and n-layers are grown in sequence on a low resistivity (n<sup>+</sup>) arsenic doped silicon substrate by vapor-phase low-pressure epitaxy. This technique provides sharp grading profiles at both the (p<sup>+</sup>)- and (n<sup>+</sup>)-interfaces and at the p-n-junction.

More than 10 years history of application of the same diodes coupled with failure analysis has enabled us to achieve very high mean-time-to-failure (MTBF) rates.

A microwave cavity test fixture is offered for both CW and pulsed IMPATT diodes. Purchase enables the user to verify ELVA-1 test data.

## CW IMPATT Diode Specifications

Model	IC-02K	IC-02Q	IC-02U	IC-02V	IC-015W	IC-005D
Test Circuit Waveguide Band (GHz)	Ka (26.5-40)	Q (33-50)	U (40-60)	V (50-75)	W (75-110)	D (110-170)
Test Frequency Range (GHz)	33-37	42-46	54-58	58-62	92-96	135-155
Power Outputs Available (W, min)	0.2	0.2	0.2	0.2	0.15	0.05
Brake Voltage Range (V)	32-40	30-38	20-26	20-26	12-15	10-12
Operating Voltage Range (V)	38-46	36-44	26-32	26-32	18-31	16-18
Operating Current, mA	80-150	80-150	100-150	100-150	150-200	180-260
Total Capacitance at V=0 (pF)	1.3-1.8	1.2-1.6	1.1-1.4	0.9-1.2	0.7-1.1	0.7-1.1



Nevsky 74, 23-H, 191025, St. Petersburg, Russia,

Tel: +7-812-326-59-24, Fax: +7-812-326-10-60

E-mail: [korneev@exch.nnz.spb.su](mailto:korneev@exch.nnz.spb.su) INTERNET <http://www.elva-1.spb.ru/>

## Pulsed IMPATT Diode Specifications

Model	IM-10PK/ IM-20PK	IM-10PV/ IM-20PV	IM-10PW/ IM-20PW	IM-01PD/ IM-02PD
Test Circuit Waveguide Band (GHz)	Ka (26.5-40)	V (50-75)	W (75-110)	D (110-170)
Test Frequency Range (GHz)	33-37	58-62	92-96	135-155
Peak Power Outputs Available (W, min)	10/20	10/20	10/20	1/2
Free Running / Amplification Modes				
Break Voltage, V	35-40	21-28	13-16	10.5-12.5
Operating Current, A	8-15	10-12	10-18	2-5
Total Capacitance at V=0 (pF)	10-26	8-12	6-8	2-6

Pulse width is 50-100 nS, repetition rate is not more than 100 kHz.

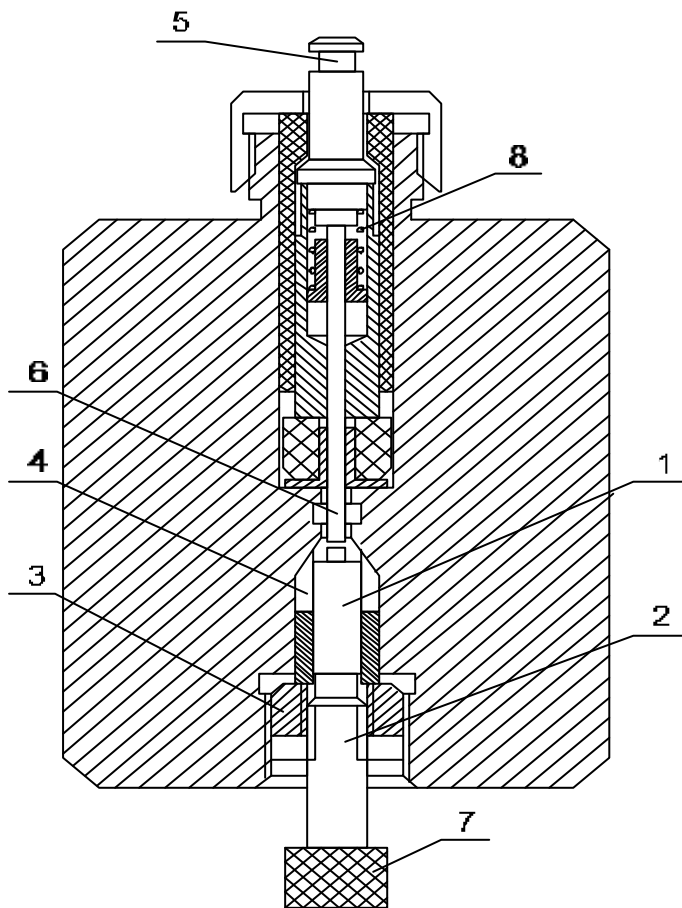

Test fixture for the testing of IMPATT Diodes for 150 GHz is designed as a coaxial-waveguide transition. IMPATT Diode (1) is installed into the coaxial line that crosses a waveguide cavity. Output of the cavity is a waveguide WR-6 with 387/U-M flange. Movable short circuit is installed on the other side of the cavity. The biasing current is applied by means of a central wire of the coaxial line (6). The construction of the test fixture allows to adjust the position of the diode in respect to the waveguide using an adjustment screw (7). The central coaxial wire is movable. There is a spring (8) that keeps a contact between the wire and the Diode during the adjustment. After the adjustment the Diode position should be fixed by means of the fixing screw (3). Adjustment of the frequency and output power should be carried out by means of two screws: micro-metric screw, that moves the short circuit, and the screw, that changes the position of the diode.

The microwave test fixture is supplied with biasing current stabilizer to provide a reliable, trouble-free operation.

Optionally we propose power supply for CW and pulsed Test Fixture 110VAC, 60Hz, or 220VAC, 50Hz.

The following products are available as examples of IMPATT diode application:

1. Cavity Stabilized IMPATT diode Oscillators **CIDO** series.
2. Pulsed IMPATT Power Sources **IPSP** series.
3. IMPATT Active Frequency Multipliers **IAFM** series.
4. Pulsed and CW IMPATT Injection-Locked Amplifiers **ILAP** and **ILA** series.
5. Voltage Controlled IMPATT Oscillators **VCIO** series.